

RENASCIMENTO

BARROCO

NEOCLÁSSICO

RENASCIMENTO

“Renascimento corresponde a uma espécie de renovação do espírito humano, à libertação [...] refinamento dos costumes, sob influência dos textos e monumentos da Antiguidade.” (Mourex, 1941)



Fig.01 A escola de Atenas de Rafael

RENAASCIMENTO

(1420 a 1620)



Fig 02 – Primavera, Botticelli

Humanismo

Pensamento racional

Observação da natureza

ANDREA PALLADIO (1508-1580)



Fig 03

“Arquiteto renascentista que uniu a antiguidade com o humanismo da sua época”. (Gympel,1996)



Fig 04 – Villa Foscari



Fig 05 – Villa Capra

Fig 06

IGREJA DO REDENTOR | andrea palladio

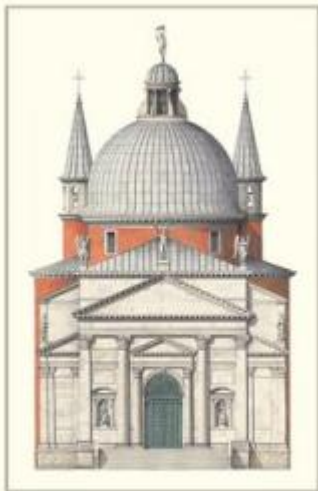


Fig 07

Igreja localizada em Veneza, na Itália
Construída de 1576 a 1591

IGREJA DO REDENTOR | andrea palladio



Fig 08



Fig 09

IGREJA DO REDENTOR | andrea palladio

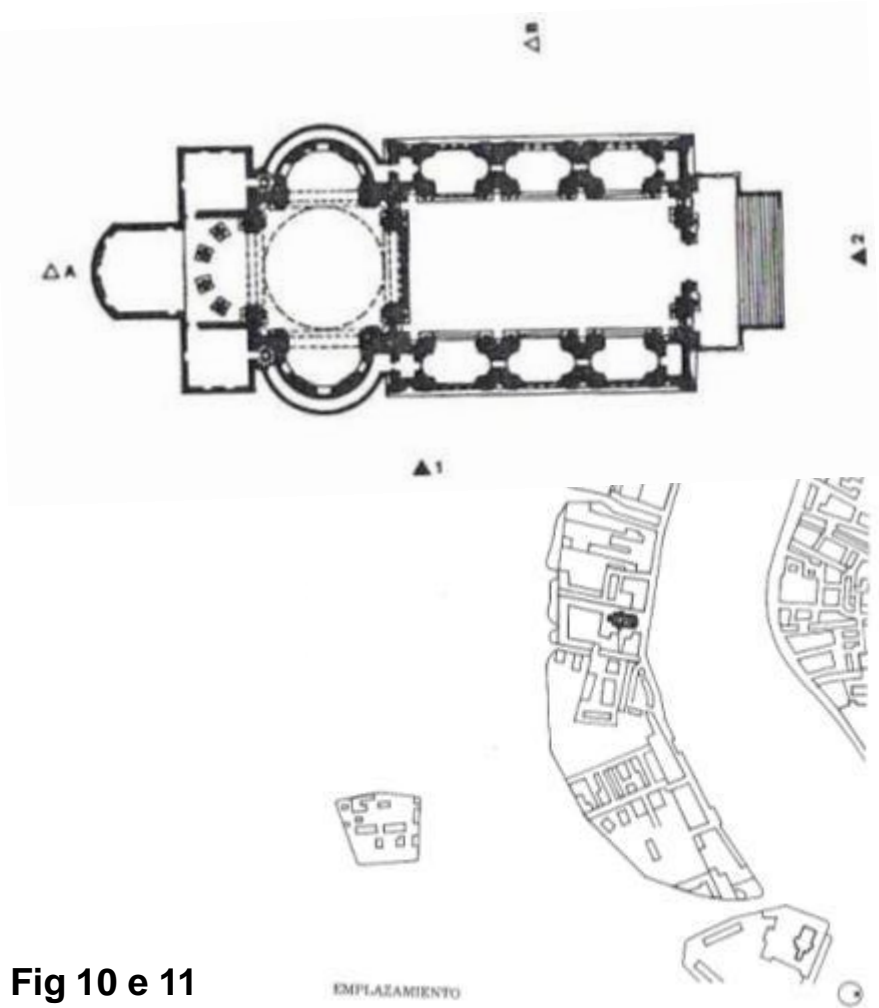
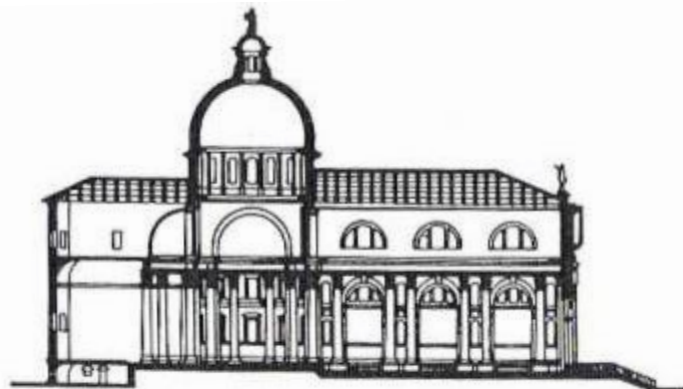


Fig 10 e 11



Fig 12

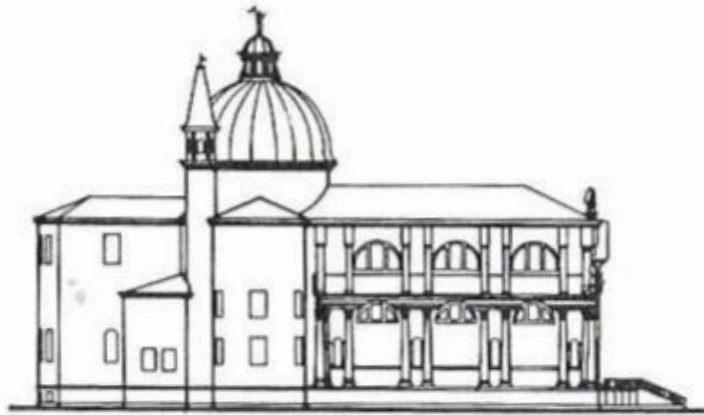
IGREJA DO REDENTOR | andrea palladio



SECCIÓN A



SECCIÓN B



ALZADO 1



ALZADO 2

Fig 13 a 15

IGREJA DO REDENTOR | andrea palladio

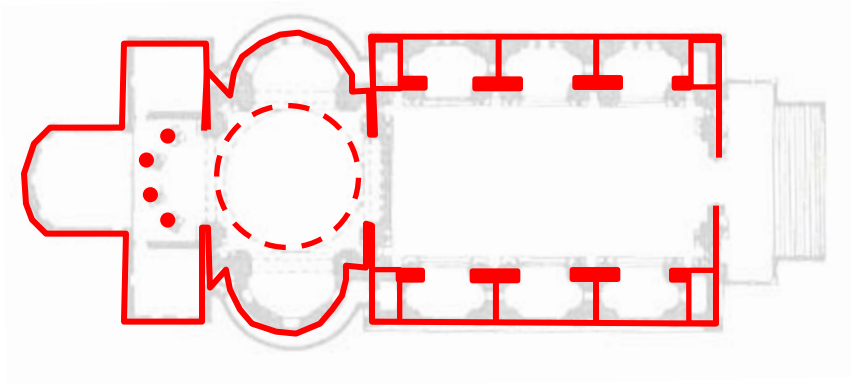


Fig 16

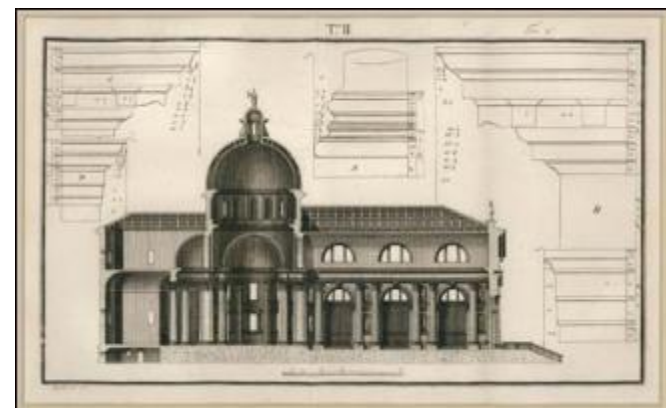
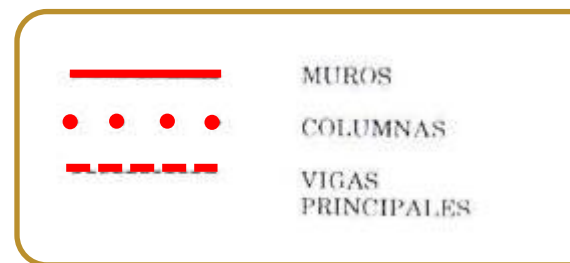


Fig 17

ESTRUTURA



IGREJA DO REDENTOR | andrea palladio

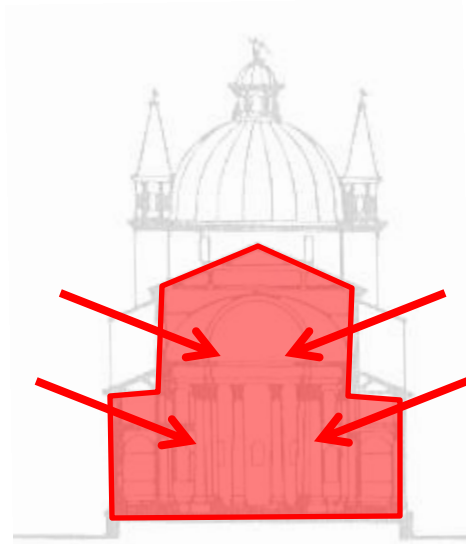


Fig 18



Fig 09

ILUMINAÇÃO NATURAL



ILUMINACIÓN NATURAL.

IGREJA DO REDENTOR | andrea palladio





Fig 19



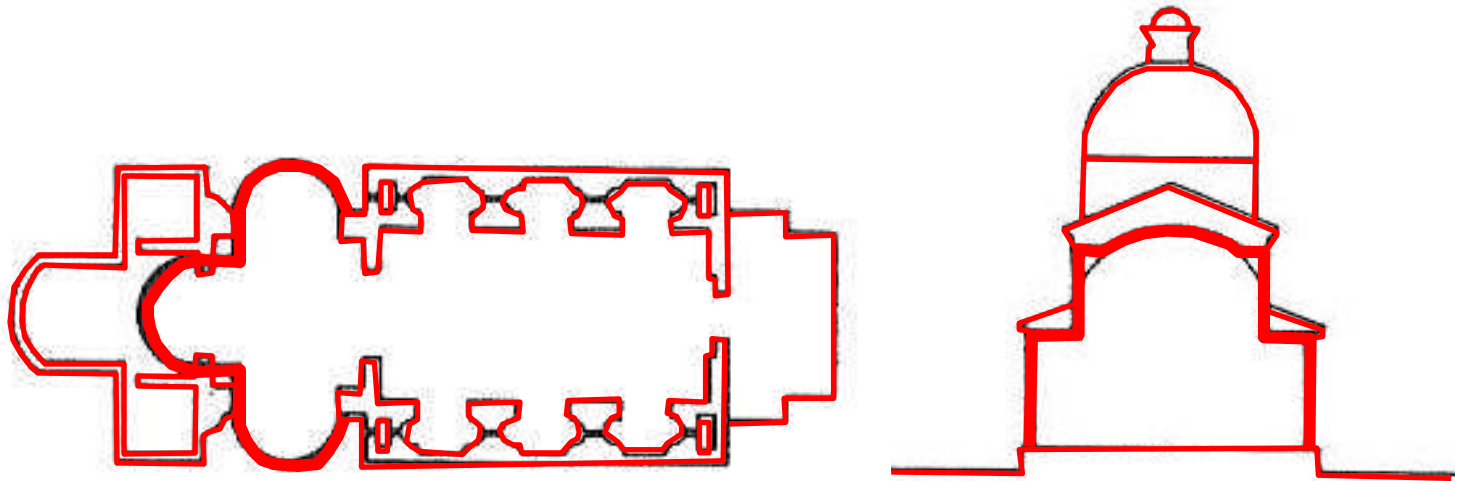
Fig 07

VENEZIA - CHIESA DEL REDENTORE

MASSA

-  MASA PRINCIPAL.
-  MASA SECUNDARIA

IGREJA DO REDENTOR | andrea palladio



PLANTA-SEÇÃO



Fig 20

IGREJA DO REDENTOR | andrea palladio

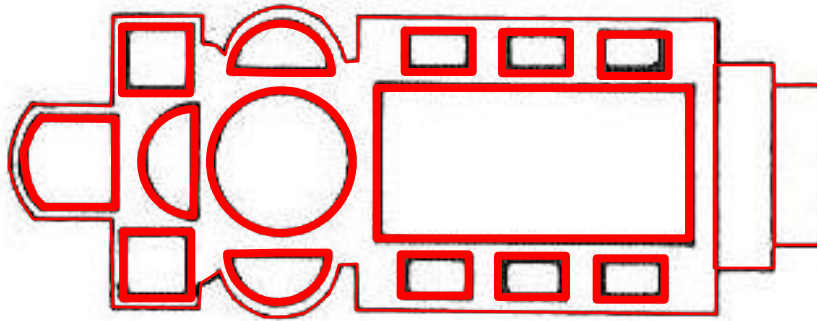




Fig 21



Fig 22

UNIDADE / CONJUNTO

-  UNIDADES
-  RESTO DEL EDIFICIO

IGREJA DO REDENTOR | andrea palladio

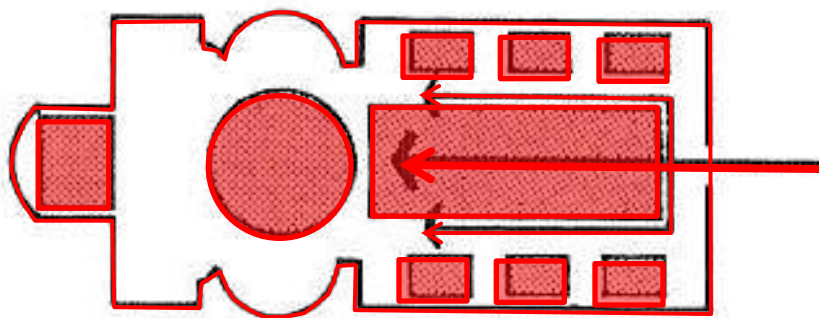


Fig 23

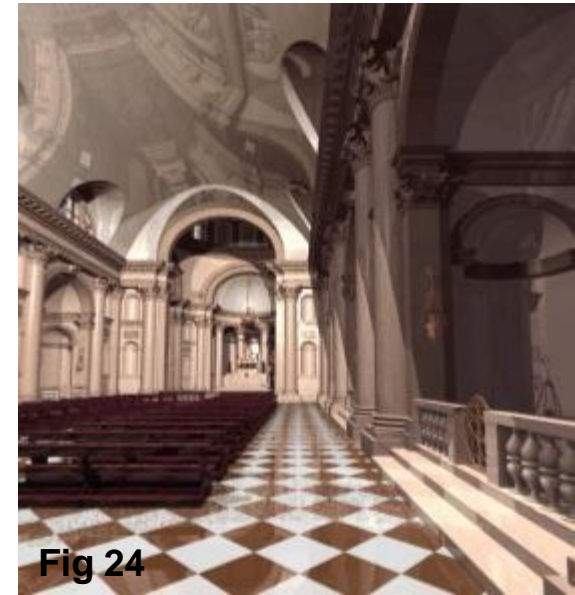
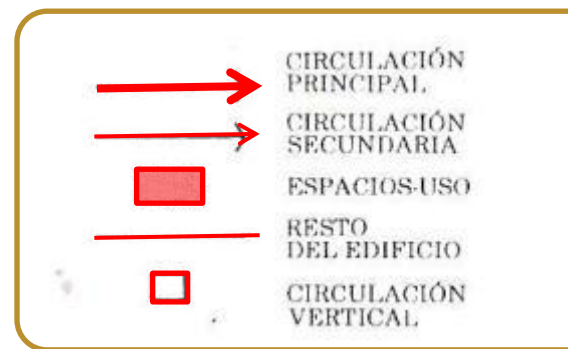
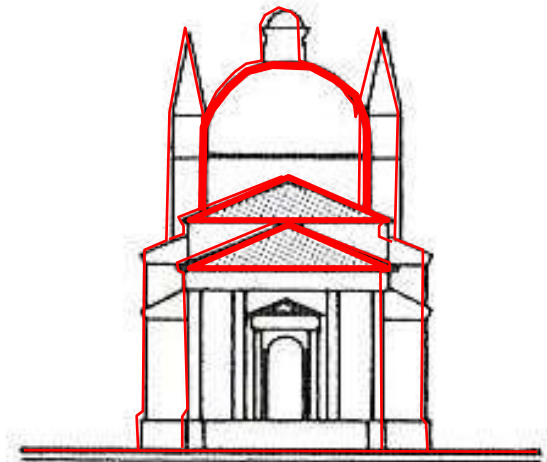
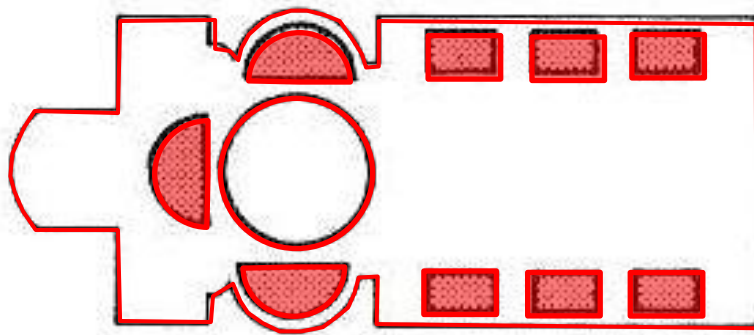


Fig 24

CIRCULAÇÃO-ESPAÇO



IGREJA DO REDENTOR | andrea palladio

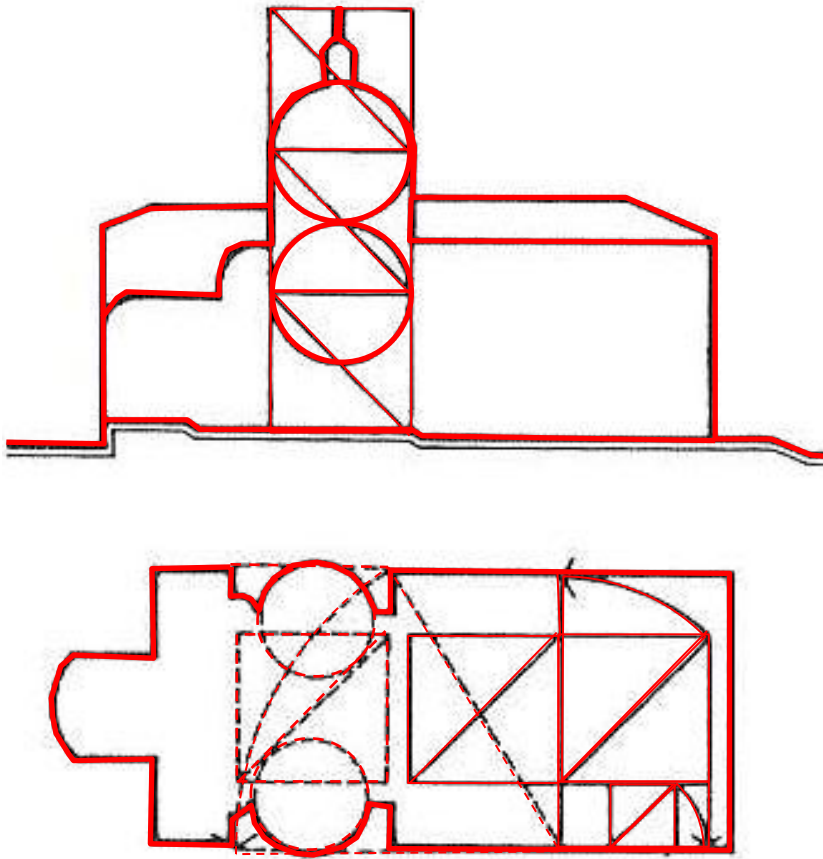


REPETITIVO-SINGULAR

- SINGULAR
- REPETITIVO
- RESTO DEL EDIFICIO

Fig 25

IGREJA DO REDENTOR | andrea palladio



GEOMETRIA


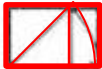



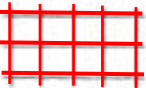

-  CUADRADO
-  RECTÁNGULO 1:4
-  RECTÁNGULO 1:6
-  DIMENSIÓN O UNIDAD
-  ÁNGULO
-  RETÍCULA
-  RADIO

Fig 26

IGREJA DO REDENTOR | andrea palladio

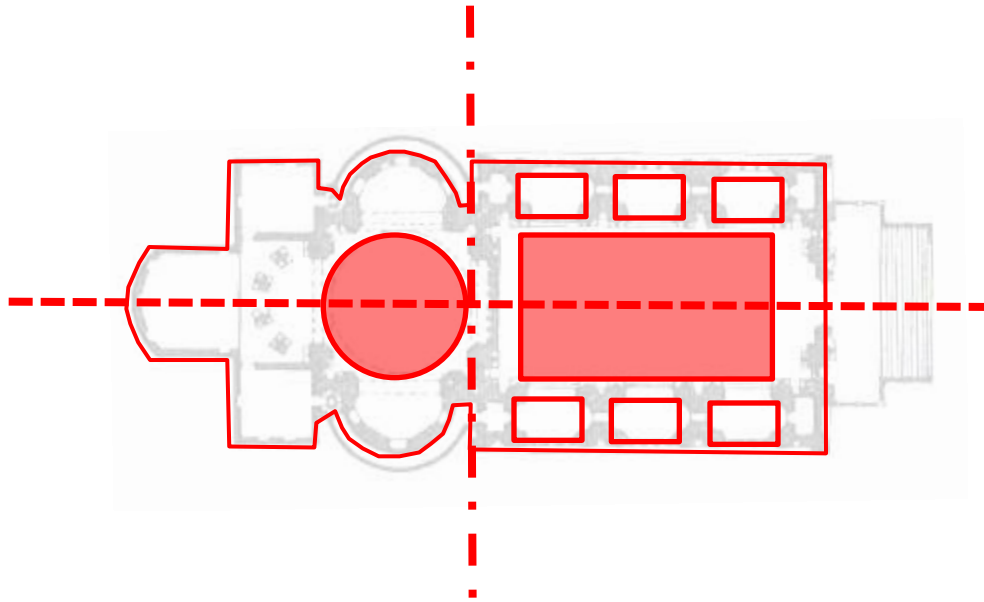








Fig 27



Fig 28

SIMETRIA E EQUILIBRIO

-  SIMETRIA TOTAL
-  SIMETRIA LOCAL
-  EQUILIBRIO TOTAL
-  EQUILIBRIO LOCAL
-  COMPONENTES DE REFERENCIA
-  PUNTO Y CONTRAPUNTO

IGREJA DO REDENTOR | andrea palladio

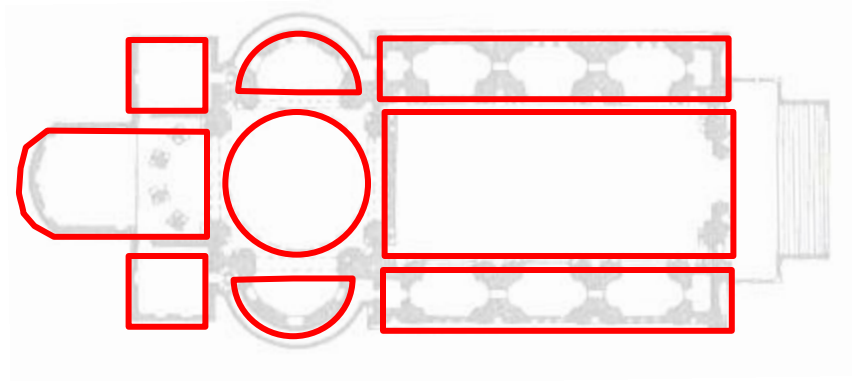
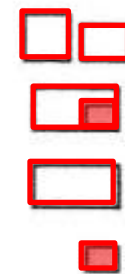


Fig 29



Fig 09

ADIÇÃO E SUBTRAÇÃO



UNIDADES
ADITIVAS

SUSTRACCIÓN

CONJUNTO

UNIDAD
SUSTRACTIVA

IGREJA DO REDENTOR | andrea palladio

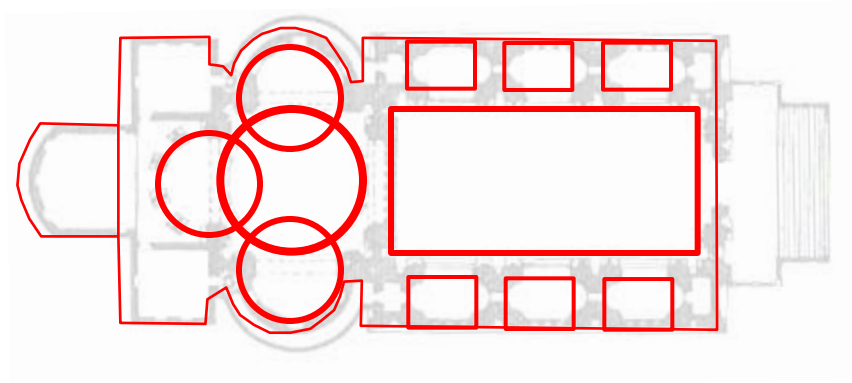





Fig 30



Fig 31

HIERARQUIA

	MÁS DOMINANTE
	A
	MENOS DOMINANTE

IGREJA DO REDENTOR | andrea palladio



Fig 32

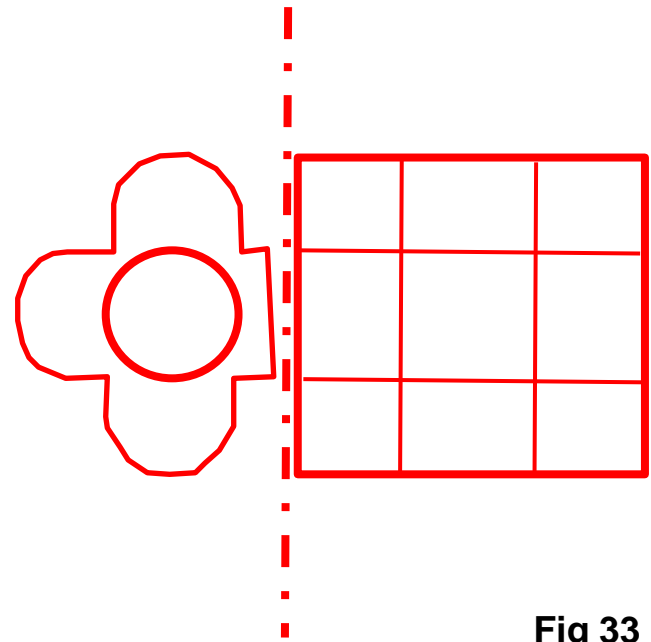


Fig 33

PARTIDO

(1600 a 1780)

“O termo barroco foi utilizado no início pejorativamente para classificar um estilo estranho e de mal gosto [...] a palavra portuguesa barroco significa pérola irregular.”
(Gympel, 1996)

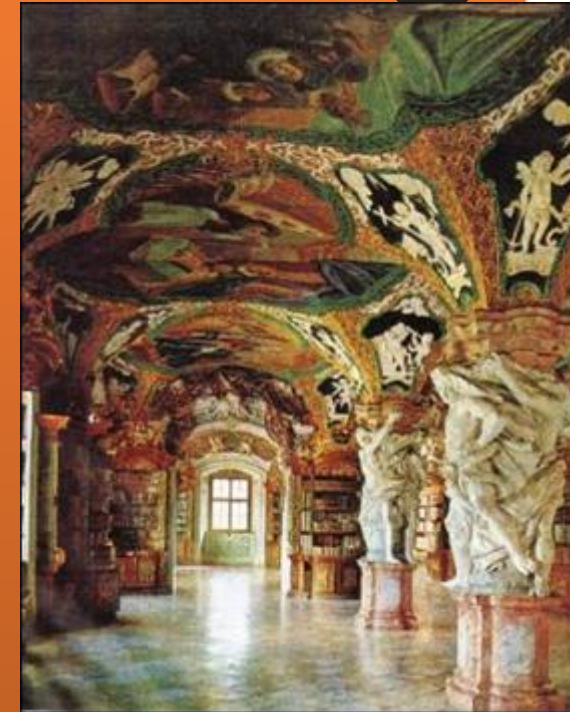


Fig 34 - Biblioteca do monastério de Metten, na Alemanha. De Franz Holzinger (1691-1775).

BARROCO



Período da Contra Reforma

Apelo dos artistas pelas curvas e pelo movimento

Efeito de ilusão

Luz e sombra

Fig 35 - Teto da Igreja de São Francisco de Assis, Manuel da Costa Ataíde (1762-1837).

BARROCO



Fig 36 a 38 - S. Carlo Alle Quattro Fontane, by Francesco Borromini, at Rome, Italy, 1638 to 1641

GIAN LORENZO BERNINI (1598 A 1680)



Fig 39

Foi um artista completo do Barroco que atuou principalmente em Roma e se destacou pela escultura e pela arquitetura. (Wikipédia, 2010)



Fig 40 – Praça de São Pedro



Fig 41 – Piazza Navona

SANT'ANDREA AL QUIRINALE | bernini

Roma – Itália, 1658 to 1665



CHIESA DEDICATA A SAN ANDREA APOSTOLO DEL NOVITIATO DE PADRI GIESVITI SVL MONTE QVIRINALE
alle quattro Fontane, Archiettura del Cau' Bernini.

1 Palazzo Pontificio
2. Novitatio de' Padri Gesuiti.

Una del de Bozzi la Stampa in Roma alla Pace, con Prand. S. P.

3. Chiesa del S^{mo} Sacramento delle Monache Capuccine.
4. Chiesa di S^{ta} Maria, Maddalena delle Monache di S. Domenico.
5. Piazza di Monte Cavallo.

13

Fig 42

BARROCO



Fig 43



Fig 44



Fig 45

SANT'ANDREA AL QUIRINALE | bernini

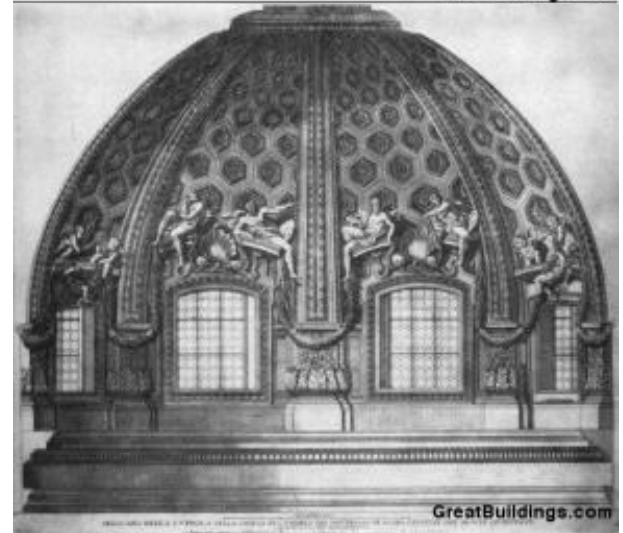
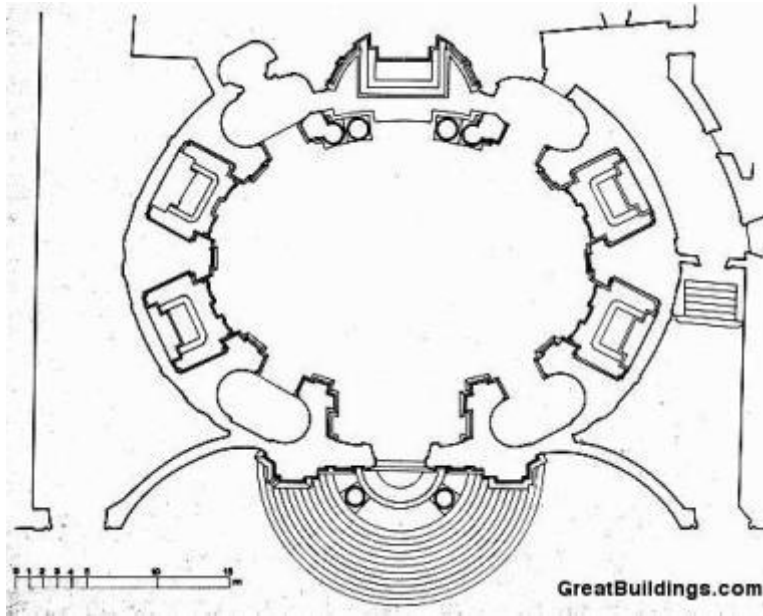
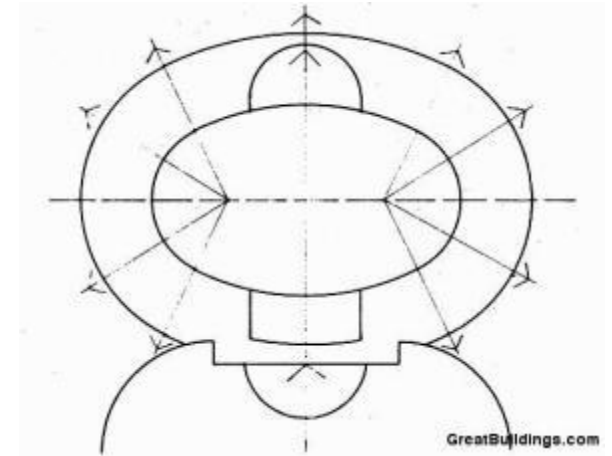
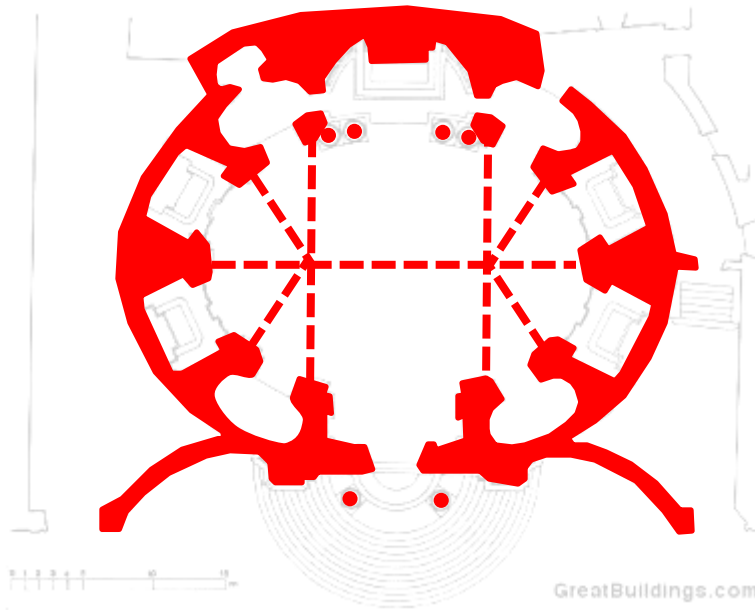


Fig 46 a 48



ESTRUTURA



MUROS



COLUMNAS



VIGAS
PRINCIPALES

Fig 49 E 50

SANT'ANDREA AL QUIRINALE | bernini

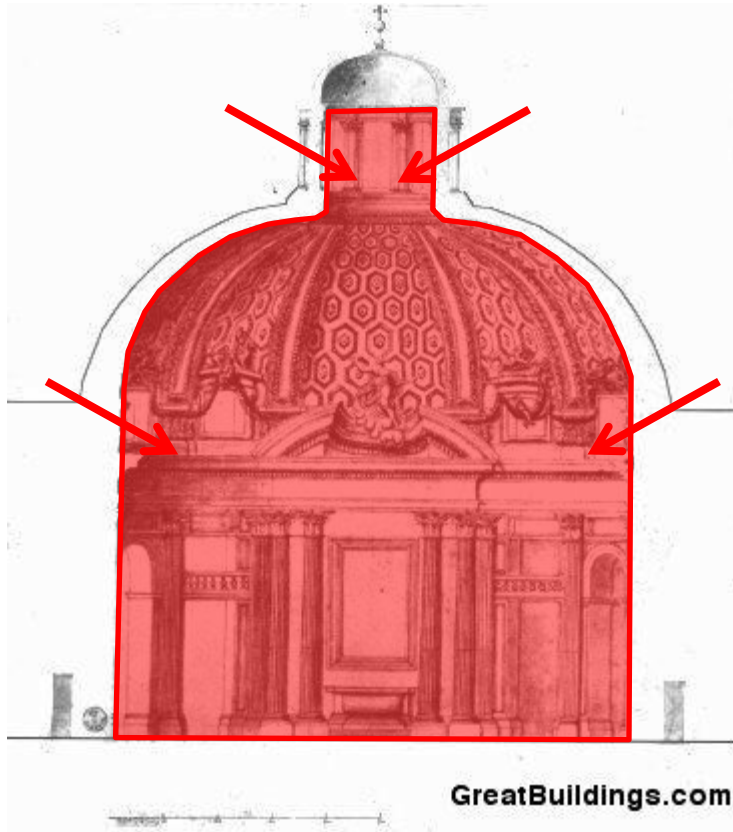


Fig 51



ILUMINAÇÃO NATURAL



ILUMINACIÓN NATURAL.

SANT'ANDREA AL QUIRINALE | bernini

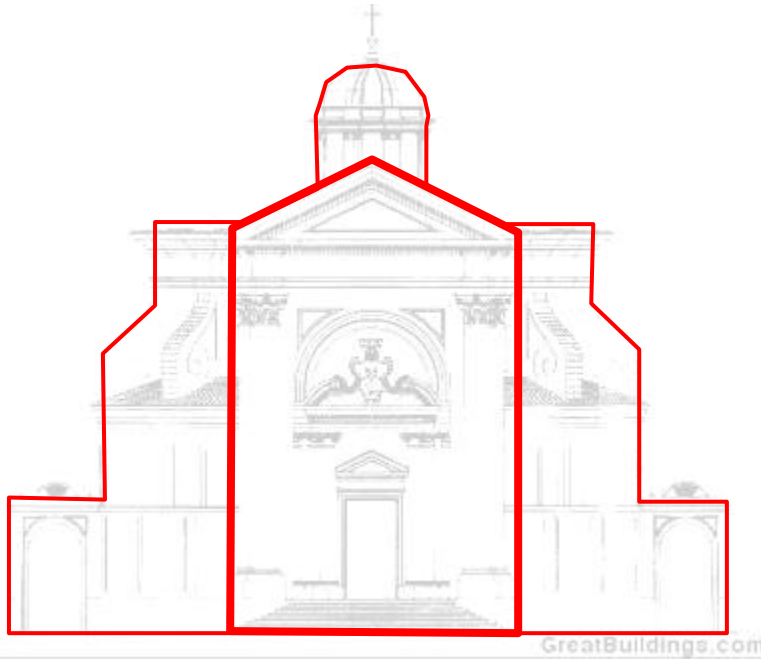




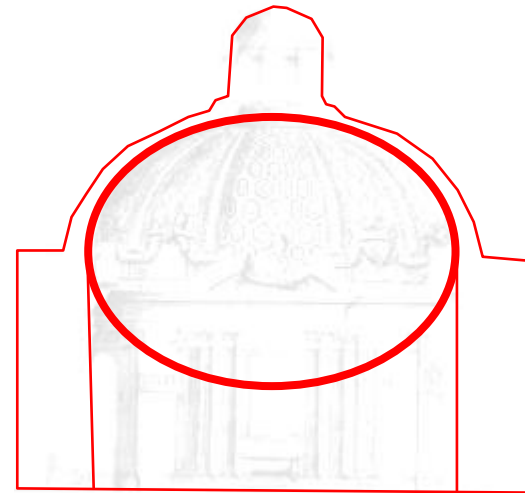
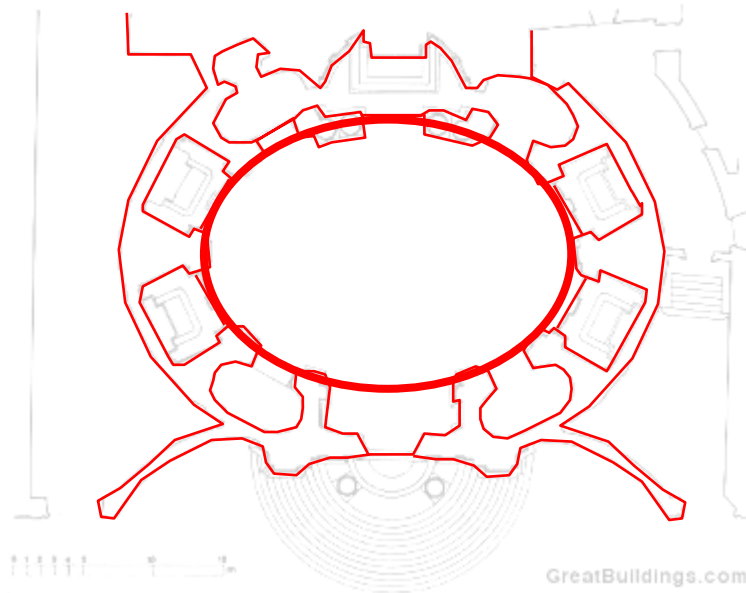
Fig 53



Fig 54

MASSA

-  MASA PRINCIPAL.
-  MASA SECUNDARIA



PLANTA-SEÇÃO



Fig 55 e 56

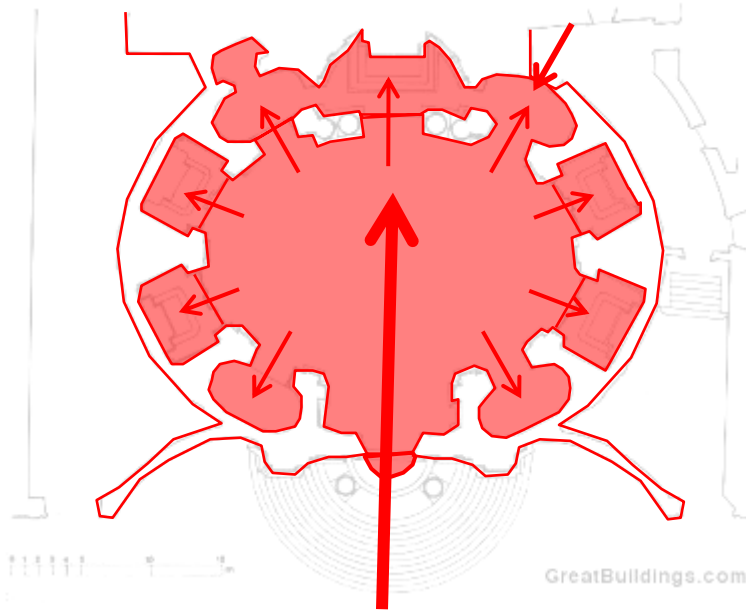
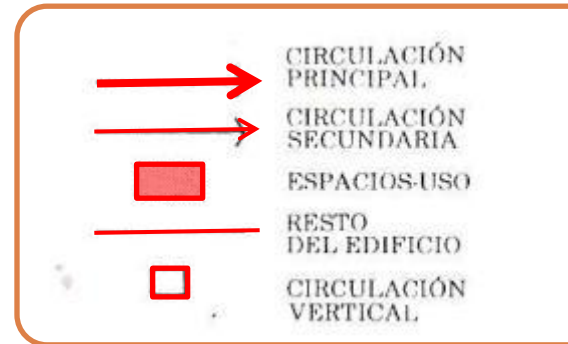


Fig 57



Fig 58

CIRCULAÇÃO-ESPAÇO



SANT'ANDREA AL QUIRINALE | bernini

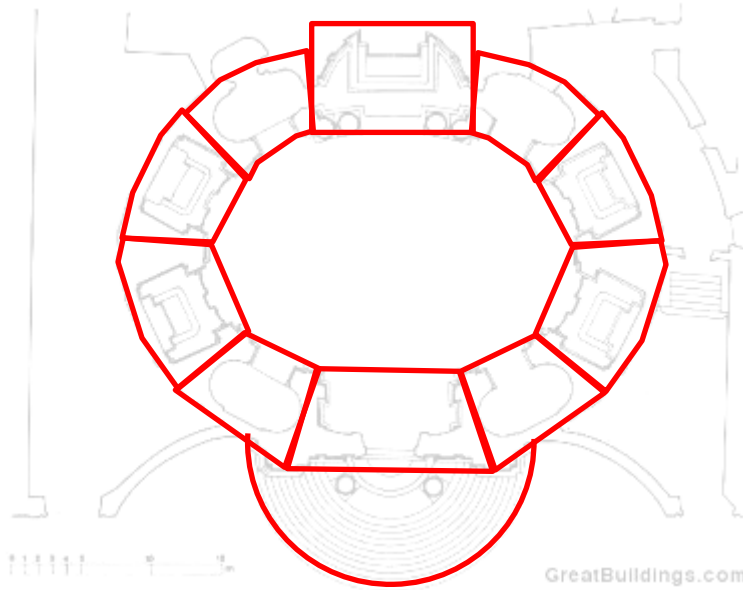




Fig 59



Fig 60

UNIDADE / CONJUNTO

-  UNIDADES
-  RESTO DEL EDIFICIO

SANT'ANDREA AL QUIRINALE | bernini

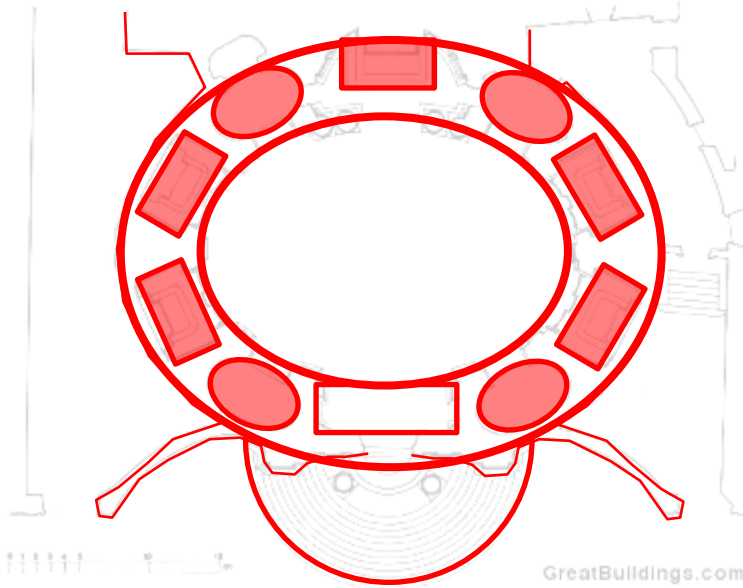


Fig 61



Fig 62

REPETITIVO-SINGULAR



SINGULAR



REPETITIVO



RESTO
DEL EDIFICIO

SANT'ANDREA AL QUIRINALE | bernini

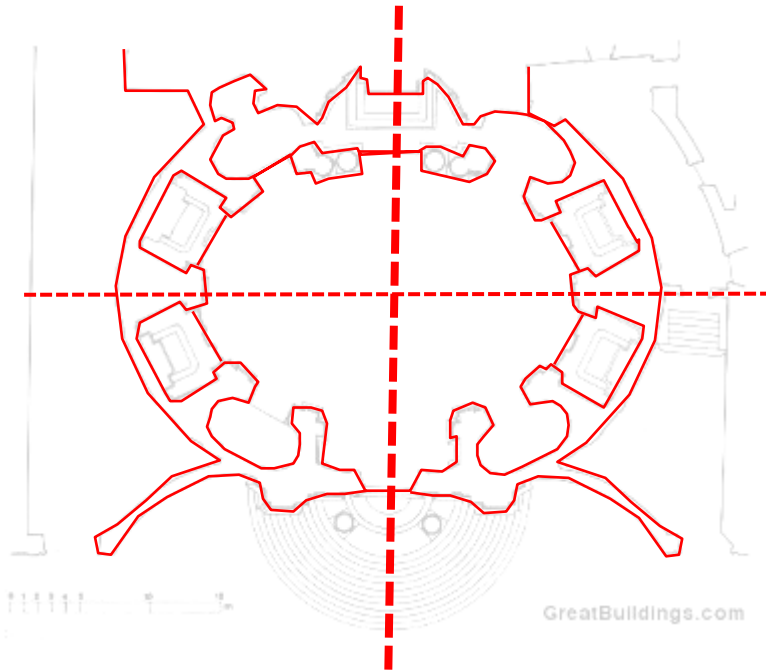


Fig 63

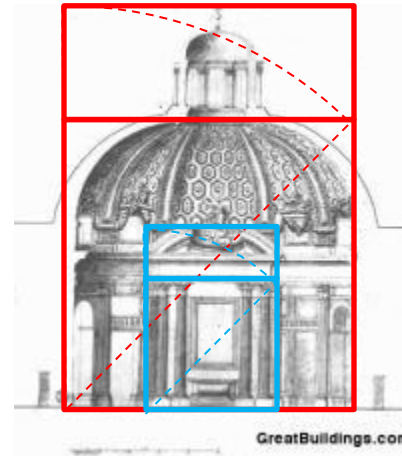
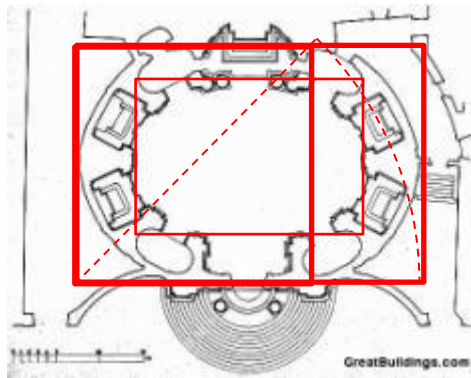


Fig 64

SIMETRIA E EQUILIBRIO

	SIMETRIA TOTAL
	SIMETRIA LOCAL
	EQUILIBRIO TOTAL
	EQUILIBRIO LOCAL
	COMPONENTES DE REFERENCIA
	PUNTO Y CONTRAPUNTO

SANT'ANDREA AL QUIRINALE | bernini



GEOMETRIA


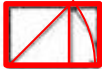



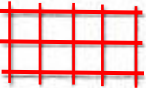

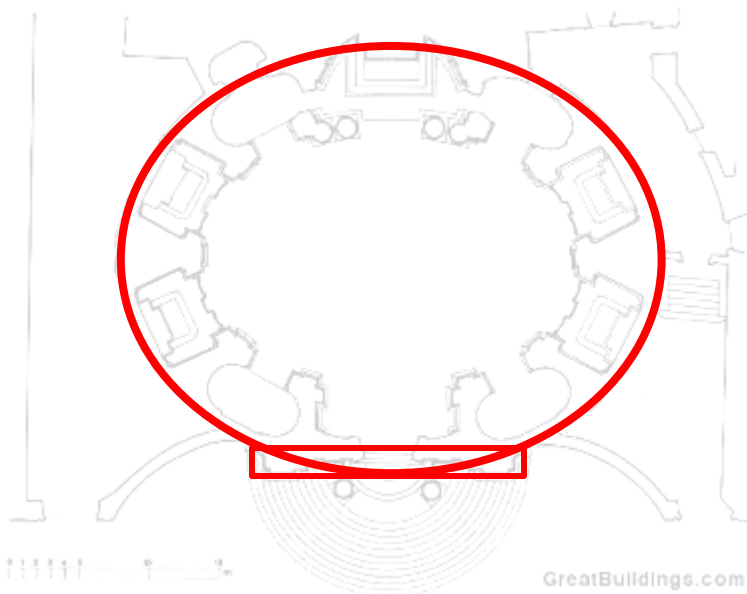
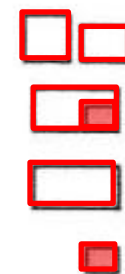
-  CUADRADO
-  RECTÁNGULO 1:4
-  RECTÁNGULO 1:6
-  DIMENSIÓN O UNIDAD
-  ÁNGULO
-  RETÍCULA
-  RADIO

Fig 66 E 67



ADIÇÃO E SUBTRAÇÃO



UNIDADES
ADITIVAS

SUSTRACCIÓN

CONJUNTO

UNIDAD
SUSTRACTIVA

Fig 68 e 69

SANT'ANDREA AL QUIRINALE | bernini

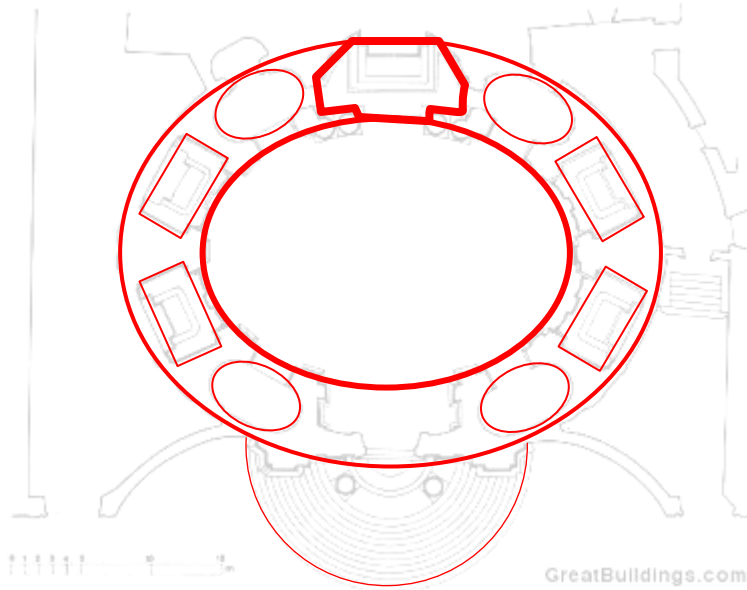
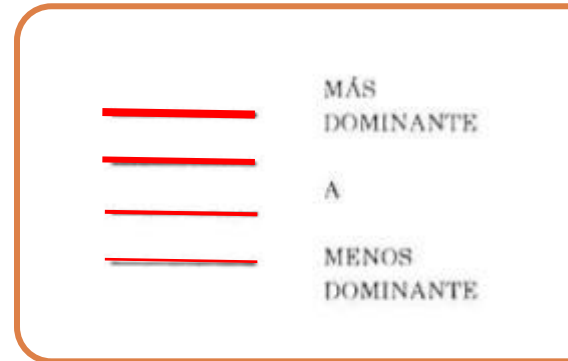


Fig 70



HIERARQUIA



SANT'ANDREA AL QUIRINALE | bernini

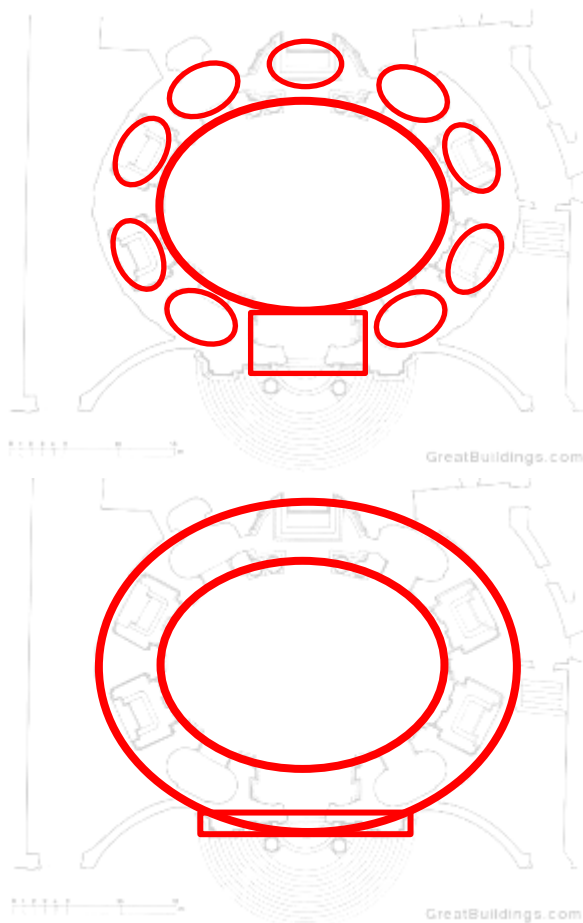


Fig 72 e 73



Fig 74

PARTIDO

(1750 a 1840)

ICO

Foi um movimento contrário ao decorativismo do barroco e rococó. Tem seus ideais no iluminismo e do classicismo.”[...] advogando os princípios da moderação, equilíbrio e idealismo.”(GONTAR, 2000)



Fig 75

EN

NICOLAY LEDOUX (1736-1806)

Pioneiro da arquitetura neoclássica francesa, sua arquitetura foi financiada pela burguesia e durante a revolução teve grande parte da sua obra destruída. (GONTAR, 2000)



Fig 76



Fig 77



Fig 78

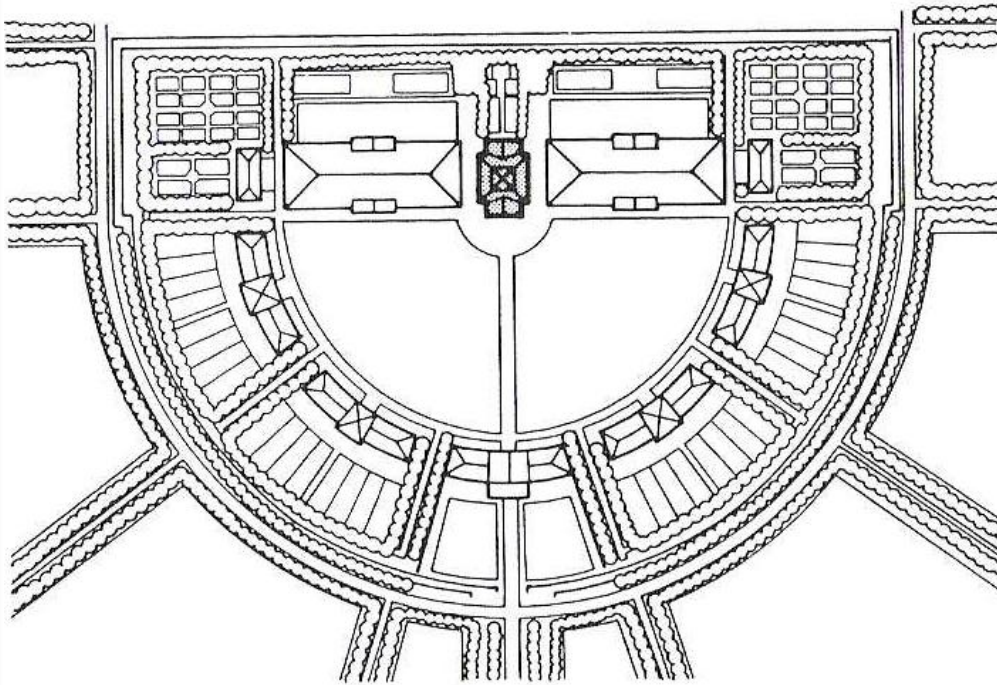
CASA DEL DIRECTOR SALINAS DE ARC Y SENANS CERCA DE
BESANÇON | ledoux



Fig 79

França
Construída de 1775-1779

CASA DEL DIRECTOR SALINAS DE ARC Y SENANS CERCA DE BESANÇON | ledoux

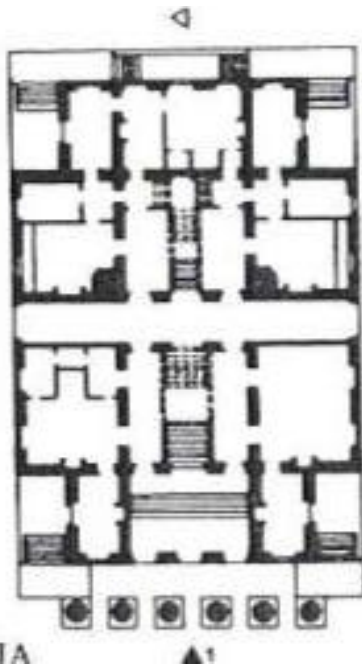


EMPLAZAMIENTO

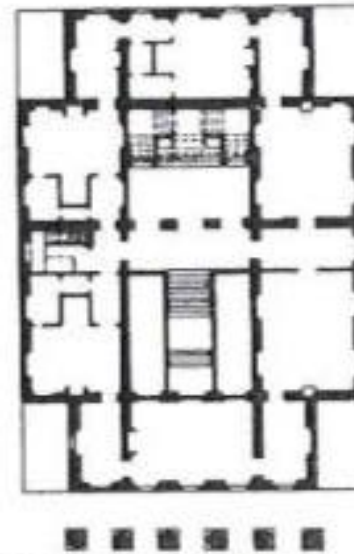
Fig 80



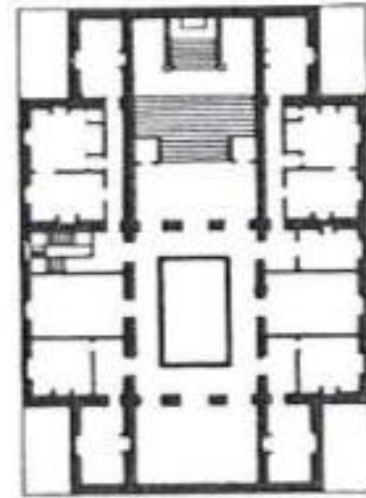
Fig 81



PLANTA BAJA

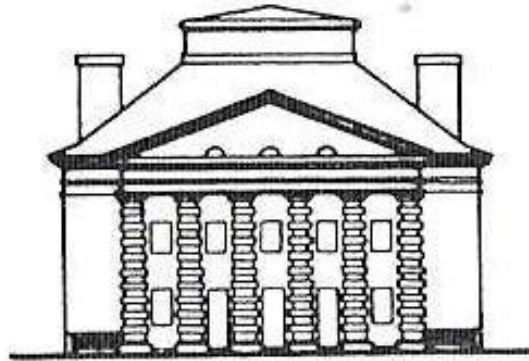


PLANTA INTERMEDIA

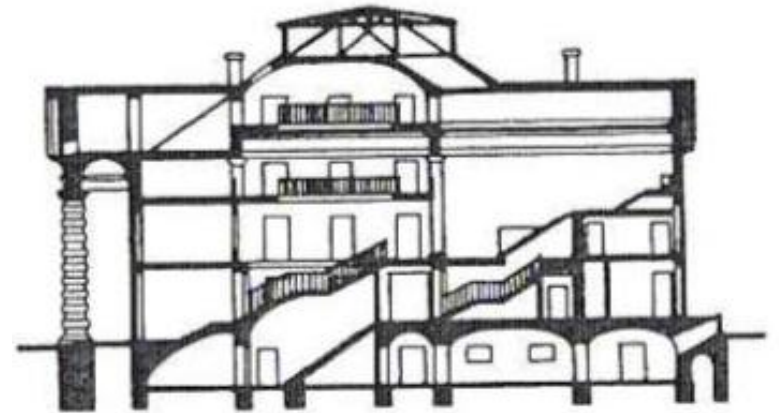


PLANTA SUPERIOR

Fig 82 à 84

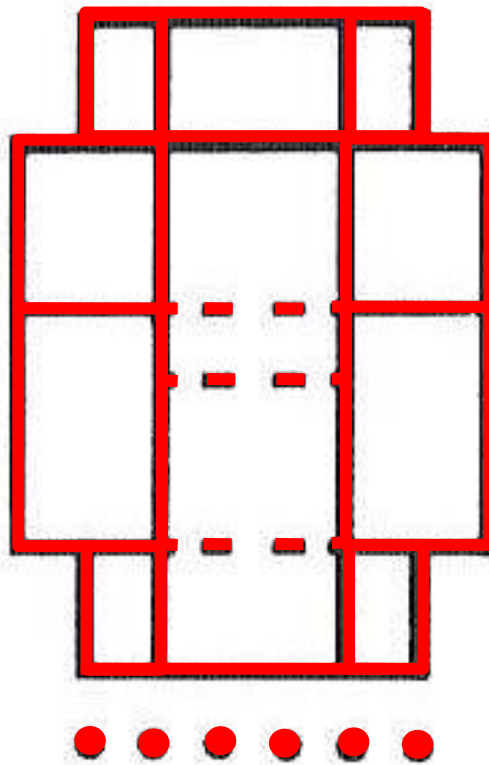


ALZADO 1



SECCIÓN A

Fig 85 e 86



ESTRUTURA



MUROS

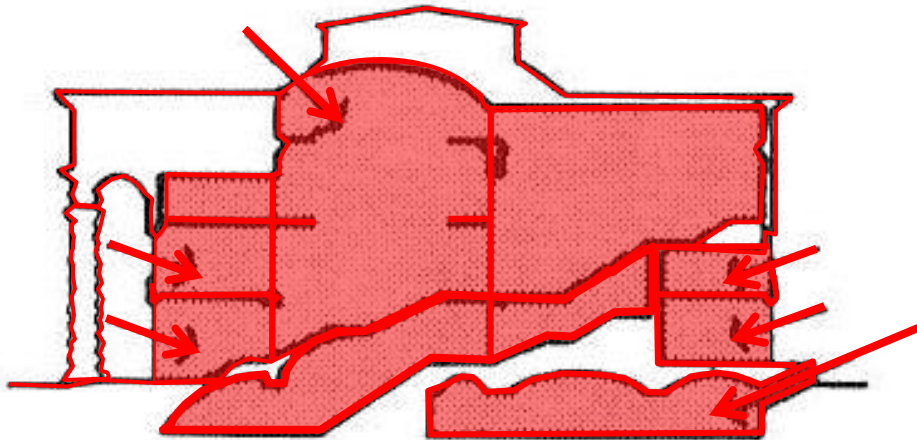


COLUMNAS



VIGAS
PRINCIPALES

Fig 87

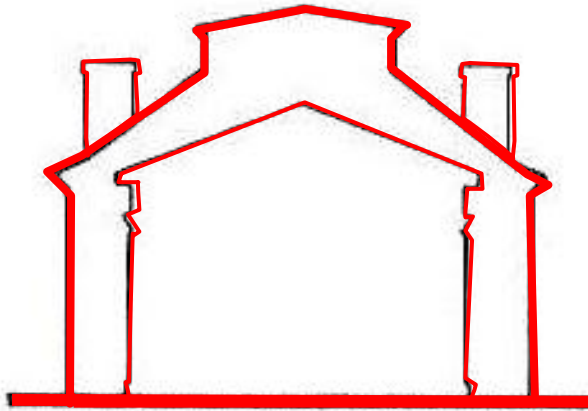


ILUMINAÇÃO NATURAL



ILUMINACIÓN NATURAL.

Fig 88



MASSA



-  MASA PRINCIPAL
-  MASA SECUNDARIA

Fig 89

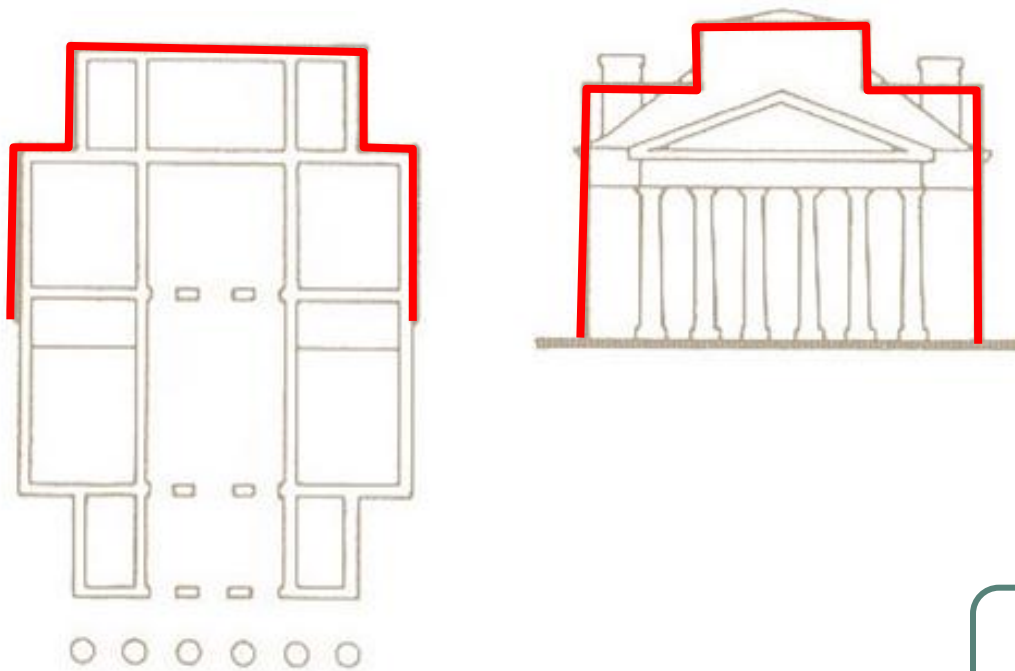


Fig 90

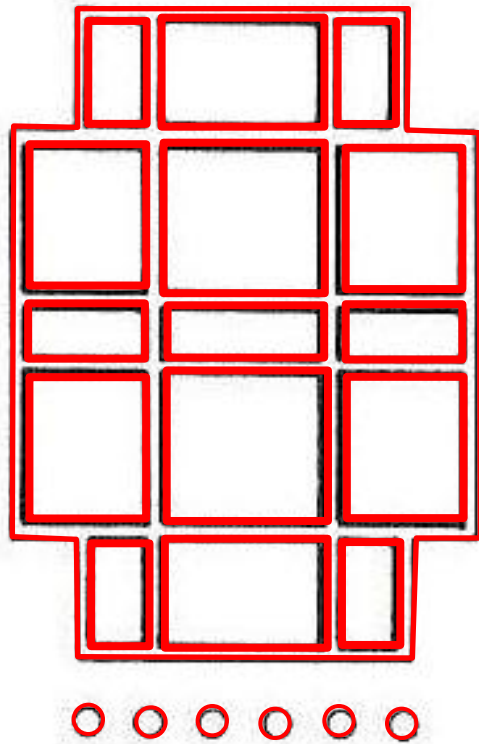


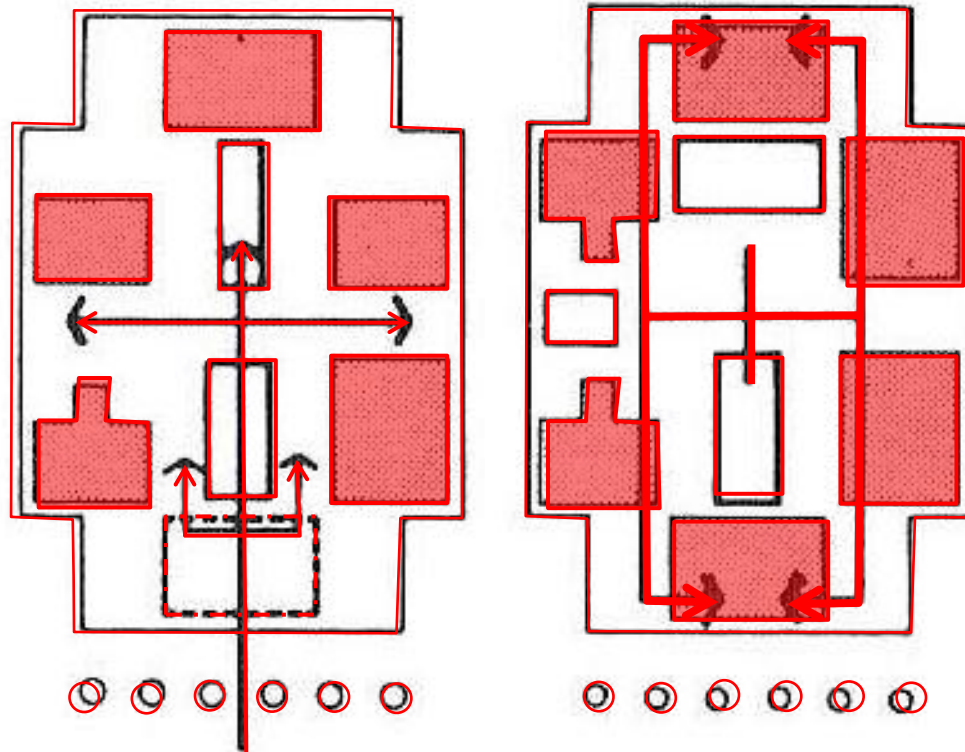


Fig 91

UNIDADE / CONJUNTO

-  UNIDADES
-  RESTO DEL EDIFICIO



CIRCULAÇÃO-ESPAÇO

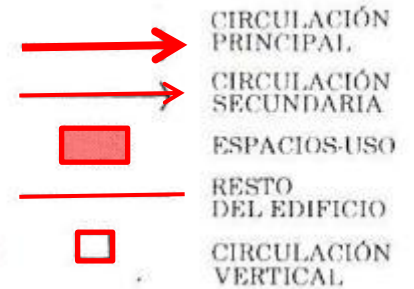


Fig 92

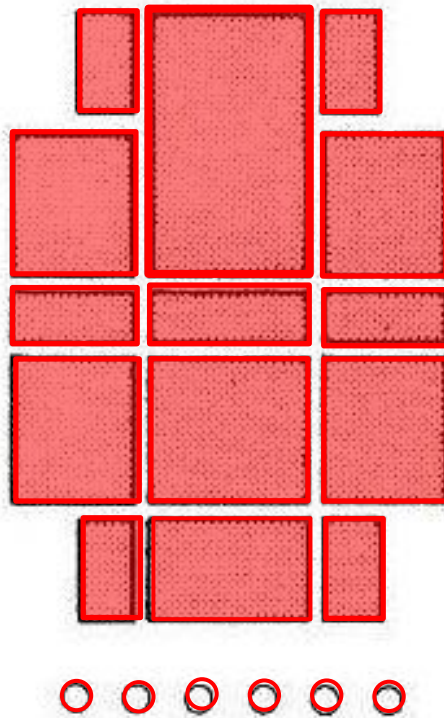
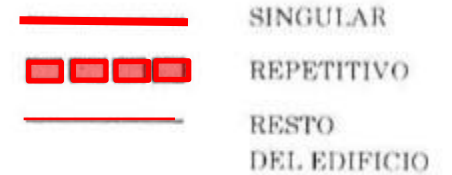
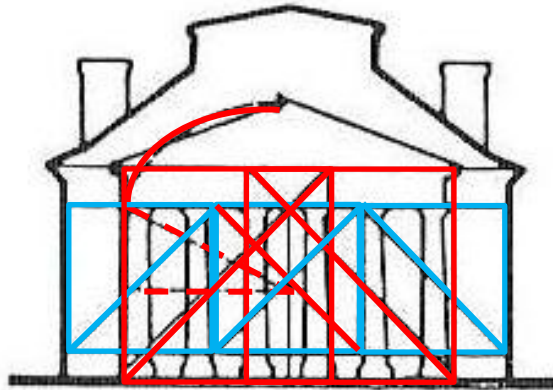
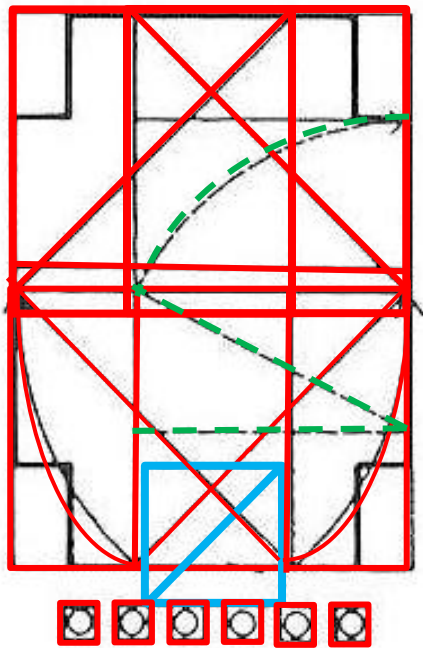


Fig 93

REPETITIVO-SINGULAR





GEOMETRIA

	CUADRADO
	RECTÁNGULO 1,4
	RECTÁNGULO 1,6
	DIMENSIÓN O UNIDAD
	ÁNGULO
	RETÍCULA
	RADIO

Fig 94

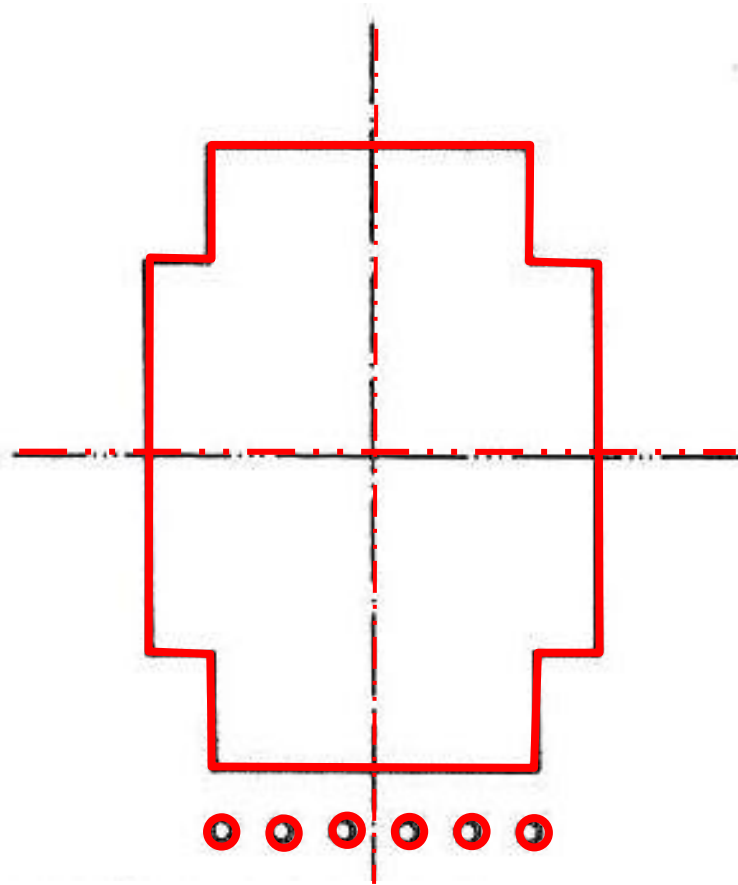








Fig 95

SIMETRIA E EQUILIBRIO

-  SIMETRÍA TOTAL
-  SIMETRÍA LOCAL
-  EQUILIBRIO TOTAL
-  EQUILIBRIO LOCAL
-  COMPONENTES DE REFERENCIA
-  PUNTO Y CONTRAPUNTO

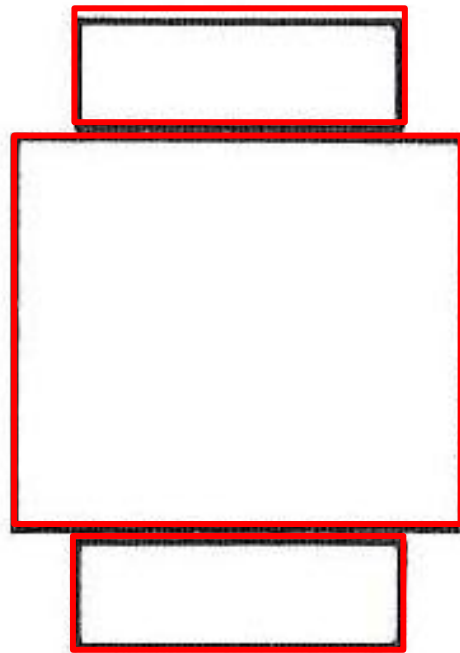


Fig 97

ADIÇÃO E SUBTRAÇÃO



UNIDADES
ADITIVAS



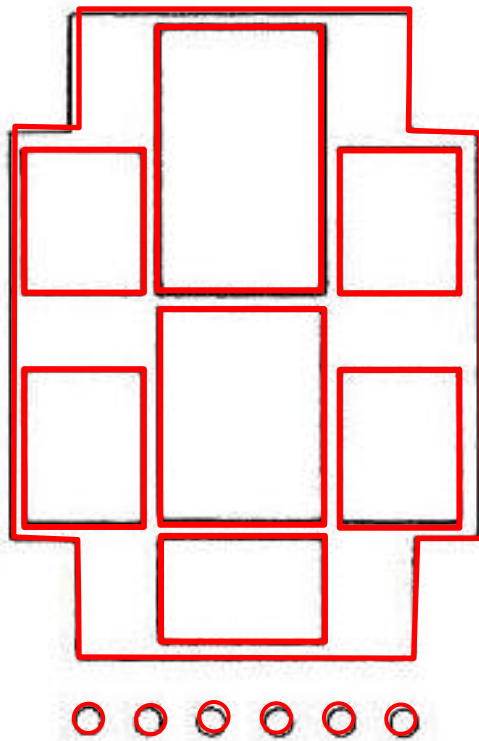
SUSTRACCIÓN



CONJUNTO



UNIDAD
SUSTRACTIVA



HIERARQUIA

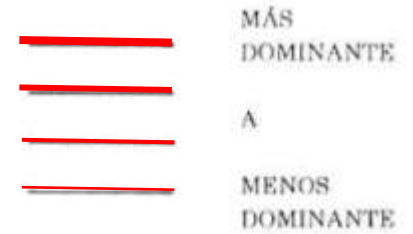


Fig 98

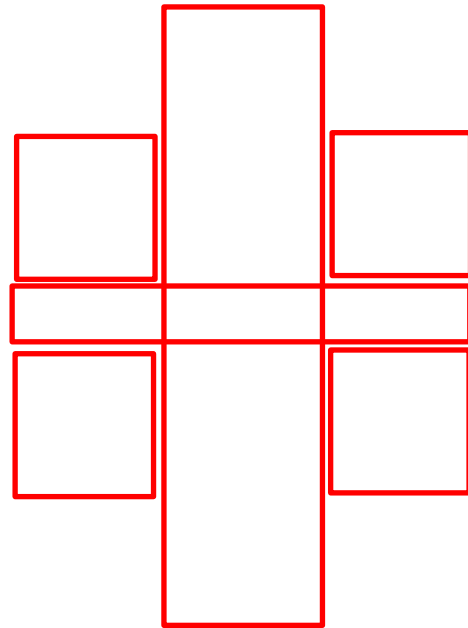


Fig 99

- CARVALHO, Benjamim de. **A história da Arquitetura**. Rio de Janeiro: Editora Tecnoprint. Edições de Ouro
- CLARK, Roger H. . **Arquitectura: temas de composicion**. Barcelona [Espanha]: G. Gili, 1983.
- COLÓNIA, Petra Lamers-Schültze. **Teoria da Arquitectura**. Do Renascimento até aos nossos dias. Taschen, 2006.
- GYMPEL, Jan. **Historia de la arquitectura**. De la Antigüedad a nuestros días. Barcelona: Könemann, 1996
- GONTAR, Cybele. *Neoclassicism*. In Heilbronn Timeline of Art History. New York: The Metropolitan Museum of Art, 2000
- MOREUX, Jean-Charles. **História da Arquitetura**. São Paulo: Editora Cultrix, 1889.
- Site Wikipédia - <http://www.wikipedia.org/>

- Fig 01 – A escola de Atenas de Rafael. Disponível em: <http://www.muqueca.blog.br/comentarios/comentarios.php?id=17>. Acesso em 03 de novembro de 2010.
- Fig 02 - **Primavera, Botticelli**. Disponível em: <http://www.historiadaarte.com.br/imagens/Botticelli1.jpg>. Acesso em 03 de novembro de 2010.
- Fig 03 – Andrea Palladio. Disponível em: <http://pt.wikipedia.org/wiki/Ficheiro:Palladio.jpg>
- Fig 04 – Villa Foscari Disponível em: <http://www.greatbuildings.com>
- Fig 05 – Villa Capra. Disponível em: <http://www.greatbuildings.com>
- Fig 06 – Igreja do Redentor. Disponível em: http://www.posterspoint.com/articulos/laminas/andrea_palladio_3286/iglesia_del_redentor,_venecia_63241
- Fig 07 – Fachada da Igreja do Redentor. Disponível em: <http://www.my-venice.com/itinerary/chiese-di-venezias.asp>
- Fig 08 e 09 – Igreja do Redentor. Disponível em: http://www.artecreha.com/Miradas_CREHA/a-palladio-iglesia-del-redentor.html
- Figura 10 e 11– Igreja do Redentor. IN: CLARK, Roger H. . **Arquitectura: temas de composicion**. Barcelona [Espanha]: G. Gili, 1983. Pág 94 e 95.
- Figura 12 - Igreja do Redentor. Disponível em: <http://goitaly.about.com/od/venicepictures/ig/Venice-Clock-Tower-Views/Venice-Giudecca-island.htm>
- Figura 13 e 16– Igreja do Redentor. IN: CLARK, Roger H. . **Arquitectura: temas de composicion**. Barcelona [Espanha]: G. Gili, 1983. Pág 94 e 95.
- Figura 17 - Igreja do Redentor. Disponível em: <http://www.italian-architecture.info/VE/VE-004.htm>
- Figura 18 e 21 – Igreja do Redentor. IN: CLARK, Roger H. . **Arquitectura: temas de composicion**. Barcelona [Espanha]: G. Gili, 1983. Pág 94 e 95.

- Figura 22 - Interior da Igreja do Redentor. Disponível em: <http://www.italian-architecture.info/VE/VE-004.htm>
- Figura 23 – Igreja do Redentor. IN: CLARK, Roger H. . **Arquitectura: temas de composicion**. Barcelona [Espanha]: G. Gili, 1983. Pág 94 e 95.
- Figura 24 – Interior da Igreja do Redentor. Disponível em: <http://www.italian-architecture.info/VE/VE-004.htm>
- Figura 25 e 27 – Igreja do Redentor. IN: CLARK, Roger H. . **Arquitectura: temas de composicion**. Barcelona [Espanha]: G. Gili, 1983. Pág 94 e 95.
- Figura 28 - Interior da Igreja do Redentor. Disponível em: <http://www.lessing-photo.com/>
- Figura 29 e 30 – Igreja do Redentor. IN: CLARK, Roger H. . **Arquitectura: temas de composicion**. Barcelona [Espanha]: G. Gili, 1983. Pág 94 e 95.
- Figura 31 - Interior da Igreja do Redentor. Disponível em: <http://www.lessing-photo.com/>
- Figura 32 - Igreja do Redentor. Disponível em: <http://briansibleysblog.blogspot.com/2009/07/feast-of-faith-and-fireworks.html>
- Figura 33– Igreja do Redentor. IN: CLARK, Roger H. . **Arquitectura: temas de composicion**. Barcelona [Espanha]: G. Gili, 1983. Pág 94 e 95.
- **Fig 34** - Biblioteca do monastério de Metten, na Alemanha. De Franz Holzinger (1691-1775). Disponível em: <http://www2.carmensalles.com.br>
- **Fig 35** - Teto da Igreja de São Francisco de Assis, Manuel da Costa Ataíde (1762-1837). Disponível em: <http://www2.carmensalles.com.br>
- **Fig 36 a 38 - S. Carlo Alle Quattro Fontane**, by Francesco Borromini, at Rome, Italy, 1638 to 1641. Disponível em: <http://www.greatbuildings.com>
- Fig 39 - GIAN LORENZO BERNINI. Disponível em: http://pt.wikipedia.org/wiki/Gian_Lorenzo_Bernini#Arquitet.C3.B4nica

- Fig 40 - *Piazza of St. Peter's · Vatican City*. Disponível em: <http://www.greatbuildings.com>
- Fig 41 - *Piazza Navona · Rome, Italy*. Disponível em: <http://www.greatbuildings.com>
- Fig 42- **S. Andrea al Quirinale**. Disponível em: <http://inillotempore.com>
- Fig 43- **S. Andrea al Quirinale**. Disponível em: <http://www.search.com/reference/Quirinale>
- Fig 44- **S. Andrea al Quirinale**. Disponível em: <http://www.flickr.com/photos/93226994@N00/19677364/>
- Fig 45 - **S. Andrea al Quirinale**. Disponível em:
- **Fig 46 a 51 - S. Andrea al Quirinale**. Disponível em: <http://www.greatbuildings.com>
- Fig 52 – Interior da Igreja - **S. Andrea al Quirinale**. Disponível em: <http://upload.wikimedia.org/wikipedia/commons/b/b4/P3090330.JPG>
- **Fig 53 - S. Andrea al Quirinale**. Disponível em: <http://www.greatbuildings.com>
- **Fig 54 - S. Andrea al Quirinale**. Disponível em: <http://aprendersociales.blogspot.com/2009/03/santandrea-al-quirinale.html>
- **Fig 55 a 57 - S. Andrea al Quirinale**. Disponível em: <http://www.greatbuildings.com>
- **Fig 58 - S. Andrea al Quirinale**. Disponível em: <http://aprendersociales.blogspot.com/2009/03/santandrea-al-quirinale.html>
- **Fig 59 - S. Andrea al Quirinale**. Disponível em: <http://www.greatbuildings.com>
- **Fig 60 – Interior da Igreja S. Andrea al Quirinale**. Disponível em: http://www.vigoenfotos.com/roma/iglesia_andrea_al_quirinale_1.html
- **Fig 61 - S. Andrea al Quirinale**. Disponível em: <http://www.greatbuildings.com>
- **Fig 62 – Interior da Igreja S. Andrea al Quirinale**. Disponível em: <http://www.flickr.com/photos/93226994@N00/19677936/>
- **Fig 63 - S. Andrea al Quirinale**. Disponível em: <http://www.greatbuildings.com>

- **Fig 64 – Fachada da Igreja de S. Andrea al Quirinale.** Disponível em: <http://www.williams.edu/art/architectureVR/santAndreaAlQuirinale/images/facade2.html>
- **Fig 65 - S. Andrea al Quirinale.** Disponível em: <http://davincidarlin.blogspot.com/2008/02/sant-andrea-mantua.html>
- **Fig 66 a 70 - S. Andrea al Quirinale.** Disponível em: <http://www.greatbuildings.com>
- **Fig 71 – Teto da Igreja S. Andrea al Quirinale.** Disponível em: <http://aprendersociales.blogspot.com/2009/03/santandrea-al-quirinale.html>
- **Fig 72 e 73 - S. Andrea al Quirinale.** Disponível em: <http://www.greatbuildings.com>
- **Fig 74 – Interior da Igreja S. Andrea al Quirinale.** Disponível em: <http://www.rositour.it/Arte/Bernini%20Gian%20Lorenzo/Bernini.htm>
- **Fig 75 – Pintura neoclássica.** Disponível em: http://urbiloquio.com/kkblog/recensioni/2007/12/il_neoclassicismo.php
- **Fig 76 – Nicolay ledoux** Disponível em: <http://www.answers.com/topic/claude-nicolas-ledoux>
- **Fig 77 – Casa del Director Salinas de Arc y Senans Cerca de Besançon** Disponível em: http://en.wikipedia.org/wiki/Claude_Nicolas_Ledoux
- **Fig 78 – Casa del Director Salinas de Arc y Senans Cerca de Besançon** Disponível em: http://travel.viamichelin.com/web/Destination/France-Burgundy_Jura-Arc_et_Senans/Tourist_Site-La_Saline_Royale-Rte_de_Salins
- **Fig 79 – Casa del Director Salinas de Arc y Senans Cerca de Besançon** Disponível em: http://www.motorhomeandaway.com/fr05_comte.htm
- **Fig 80 – Casa del Director Salinas de Arc y Senans Cerca de Besançon** IN: CLARK, Roger H. . **Arquitectura: temas de composicion.** Barcelona [Espanha]: G. Gili, 1983. Pág 70 e 71.
- **Fig 81 – Implantação da Casa del Director Salinas de Arc y Senans Cerca de Besançon** Disponível em: http://www.wan-governance.com/my_weblog/2009/07
- **Fig 82 – Casa del Director Salinas de Arc y Senans Cerca de Besançon** IN: CLARK, Roger H. . **Arquitectura: temas de composicion.** Barcelona [Espanha]: G. Gili, 1983. Pág 70 e 71.
- **Fig 83 – Casa del Director Salinas de Arc y Senans Cerca de Besançon** IN: CLARK, Roger H. . **Arquitectura: temas de composicion.** Barcelona [Espanha]: G. Gili, 1983. Pág 70 e 71. **Fig 84 – Casa del Director Salinas de Arc y Senans Cerca de Besançon** IN: CLARK, Roger H. . **Arquitectura: temas de composicion.** Barcelona [Espanha]: G. Gili, 1983. Pág 70 e 71.
- **Fig 85 – Casa del Director Salinas de Arc y Senans Cerca de Besançon** IN: CLARK, Roger H. . **Arquitectura: temas de composicion.** Barcelona [Espanha]: G. Gili, 1983. Pág 70 e 71.
- **Fig 86 – Casa del Director Salinas de Arc y Senans Cerca de Besançon** IN: CLARK, Roger H. . **Arquitectura: temas de composicion.** Barcelona [Espanha]: G. Gili, 1983. Pág 70 e 71.

- **Fig 87–Casa del Director Salinas de Arc y Senans Cerca de Besançon** IN: CLARK, Roger H. . **Arquitectura: temas de composicion.** Barcelona [Espanha]: G. Gili, 1983. Pág 70 e 71.
- **Fig 88 –Casa del Director Salinas de Arc y Senans Cerca de Besançon** IN: CLARK, Roger H. . **Arquitectura: temas de composicion.** Barcelona [Espanha]: G. Gili, 1983. Pág 70 e 71.
- **Fig 89 –Casa del Director Salinas de Arc y Senans Cerca de Besançon** IN: CLARK, Roger H. . **Arquitectura: temas de composicion.** Barcelona [Espanha]: G. Gili, 1983. Pág 70 e 71.
- **Fig 90 –Casa del Director Salinas de Arc y Senans Cerca de Besançon** IN: CLARK, Roger H. . **Arquitectura: temas de composicion.** Barcelona [Espanha]: G. Gili, 1983. Pág 70 e 71.
- **Fig 91 –Casa del Director Salinas de Arc y Senans Cerca de Besançon** IN: CLARK, Roger H. . **Arquitectura: temas de composicion.** Barcelona [Espanha]: G. Gili, 1983. Pág 70 e 71.
- **Fig 92 –Casa del Director Salinas de Arc y Senans Cerca de Besançon** IN: CLARK, Roger H. . **Arquitectura: temas de composicion.** Barcelona [Espanha]: G. Gili, 1983. Pág 70 e 71.
- **Fig 93 –Casa del Director Salinas de Arc y Senans Cerca de Besançon** IN: CLARK, Roger H. . **Arquitectura: temas de composicion.** Barcelona [Espanha]: G. Gili, 1983. Pág 70 e 71.
- **Fig 94 –Casa del Director Salinas de Arc y Senans Cerca de Besançon** IN: CLARK, Roger H. . **Arquitectura: temas de composicion.** Barcelona [Espanha]: G. Gili, 1983. Pág 70 e 71.
- **Fig 95 –Casa del Director Salinas de Arc y Senans Cerca de Besançon** IN: CLARK, Roger H. . **Arquitectura: temas de composicion.** Barcelona [Espanha]: G. Gili, 1983. Pág 70 e 71.
- **Fig 96 –Casa del Director Salinas de Arc y Senans Cerca de Besançon** IN: CLARK, Roger H. . **Arquitectura: temas de composicion.** Barcelona [Espanha]: G. Gili, 1983. Pág 70 e 71.
- **Fig 97 –Casa del Director Salinas de Arc y Senans Cerca de Besançon** IN: CLARK, Roger H. . **Arquitectura: temas de composicion.** Barcelona [Espanha]: G. Gili, 1983. Pág 70 e 71.
- **Fig 98 –Casa del Director Salinas de Arc y Senans Cerca de Besançon** IN: CLARK, Roger H. . **Arquitectura: temas de composicion.** Barcelona [Espanha]: G. Gili, 1983. Pág 70 e 71.
- **Fig 99 – Casa del Director Salinas de Arc y Senans Cerca de Besançon** IN: CLARK, Roger H. . **Arquitectura: temas de composicion.** Barcelona [Espanha]: G. Gili, 1983. Pág 70 e 71.